

PDF
PATTERN
Download

Sharon
Holland
DESIGNS

Free Pattern
Size: 5" x 4"



NEEDLE CASE

Skill Level: Beginner

Size: 5" x 4"

Designer/Maker: Sharon Holland

MATERIALS

- (1) 8" square and (1) 1-½" x 3" rectangle exterior fabric
- (1) 8" square lining fabric
- (1) 8" square of light to medium-weight fusible interfacing
- 1-½" x 3" rectangle of felt
- 5" length of ⅝" wide Dritz Fold-Over or Ruffle Elastic
- 1 sew-on snap

Read through all instructions before beginning. Sew pieces right sides together and use a ¼" seam allowance throughout unless otherwise stated. Remove the selvages.

SEW

1. According to the manufacturer's instructions, fuse the interfacing onto the wrong side of lining print, matching edges.

2. Stack the exterior print and fused lining print, right sides together with edges matched. Mark 2" away from each side of each corner. With a ruler and rotary cutter, cut a diagonal line on all four side to clip off corner, cutting through all layers.

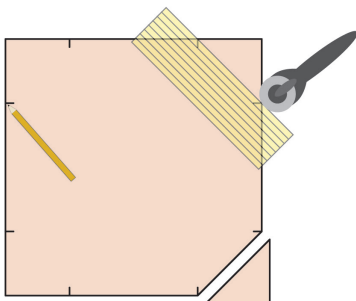

3. Fold the lining octagon in half with rights sides together. Press to crease. With octagon slightly open, push sides in at same time to form the basket shape with gusseted sides. When shape is symmetrical, press to crease. Note: The sample has a 2" base.

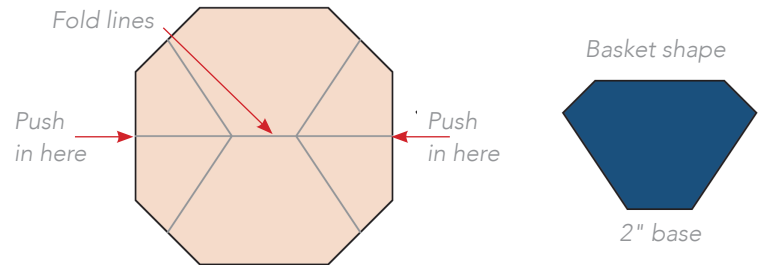

4. On the right side of lining, use the creases as a guide and pin the felt rectangle within the large opening area on one half of the case. Stitch in place around all sides with a machine zigzag or decorative stitch. On the opposite open area, stitch the elastic in place by first turning both ends ¼" under. Stitch the center of elastic down to make 2 thread holders.

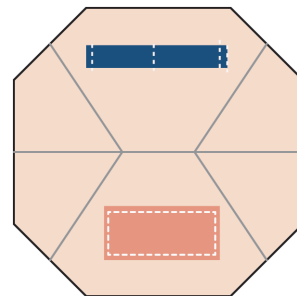

5. Press the 1-½" x 3" exterior rectangle in half lengthwise, wrong sides together. Open up and press the long raw edges in to center crease. Refold on crease, encasing raw edges. Stitch near to edge to close. Fold loop in half. With raw edges matching and loop centered on the rights side of lining along one edge of open area, baste with a ⅛" seam allowance.

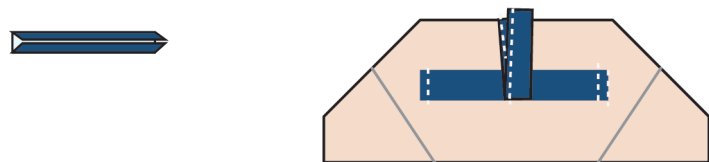

6. With right sides together and edges matching, place lining on exterior octagon. Sew with ¼" seam allowance around all sides, leaving a 2" opening for turning. Clip corners; turn right side out. Press opening under ¼". Stitch around outer edge with a ⅛" seam allowance to close opening and finish the edges. Press to reestablish gusset sides and reshape needle case, being careful not to touch the elastic with the iron. Make sure sides are symmetrical and handle is centered.

7. Position snap on the inside of case just below the loop. Hand stitch in place, hiding threads between layers.